

STONE

Reinventing the coffee space.

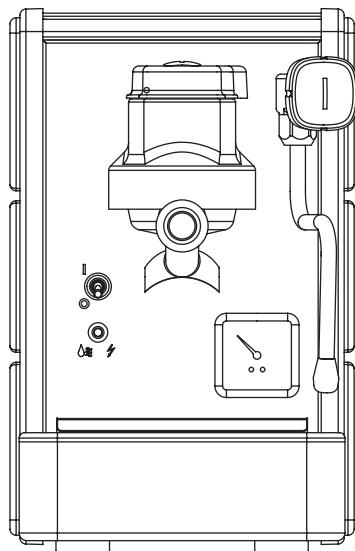

English

A coffee machine that enhances your favorite origins. With Stone you will savor every nuance of your espresso. No more compromises—satisfy your passion for coffee.



Your kitchen becomes a gourmet coffee bar.



Optimum temperature stability, better results in the cup. Beautiful and compact, but with no compromises. Stone's design seduces and its thermal stability conquers. No plastic parts, only metal, meaning better and more consistent results in the cup.

Fast ignition.

STONE is ready in just 10 minutes. Save time, enjoy your coffee or cappuccino in serenity, and start the day in a great way.

Innovation takes shape.

Crafted with high-quality materials for a unique design, STONE packs its professional technology in a compact domestic size.

The pleasure of choice.

Discover all the stylistic combinations and choose the Stone that suits you best. The choice is yours, but the quality always remains at its highest level.

Pure

Side Panel: Grey



Slab: Grey

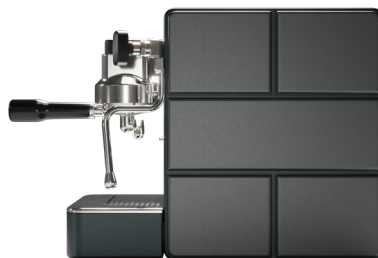

Plus

Side Panel: Black



Slab: Black



Mine

Side Panel: Satin



Slab: Black, Green

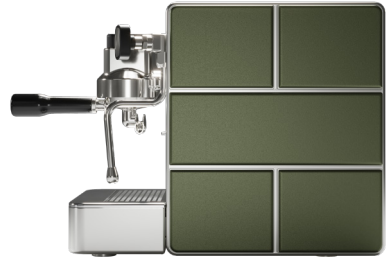

Mine Premium

Side Panel: Chrome



Slab: Satin



Mine Premium Wood

Side Panel: Chrome



Slab: Wood



Match it to your decor.

Rustic or industrial – whatever the style of your kitchen, with Slab choose the design you desire for your environment.





STONE changes with you.

Thanks to the quick coupling system, replacing the Slabs is fast and easy. So, if you change your house or decor, STONE can change with you.

Innovation takes shape.

- **Single boiler (1.5 L)**, equipped with a 1000W heater, crossed by an internal coil path for coffee water heating (100 cc).
- **Heavy brass group (>3 kg)** and PID-controlled heating system (200W) for a stable and constant brew temperature.
- **Steam chamber 0.8 L** for constant steam supply even during coffee brewing.
- **Removable water tank (1.2 L).**
- **ECO mode available.**
- **RGB led control light** for machine status and warnings.
- **Compact dimensions:** 22.5 cm x 44 cm x 35.5 cm (width x depth x height).
- **Total Weight:** 20.5 Kg.
- **220-240V 50/60Hz** and **115V 60Hz** versions available.
- **Stainless steel panels and fully customizable aluminum side elements** (different colors and materials available).
- **On-line configurator tool** to build and order your own machine.

Technical information.

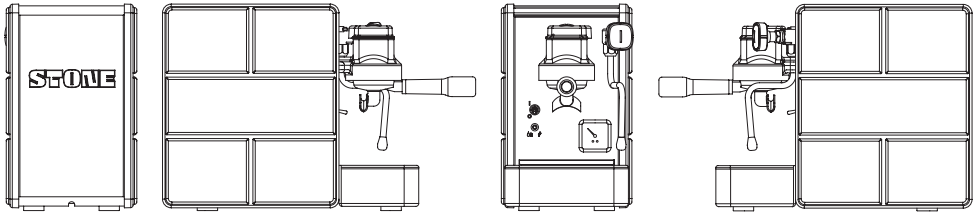

Measurements

Width

225 mm

Height

355 mm

Depth

440 mm

Weight

20.5 kg

Heater

1000 W

Heating System

200 W

Single Boiler Capacity

1.5 L

Steam Chamber

0.8 L

Removable water tank

1.2 L

Wattage - Version A

220-240 V - 50/60 Hz

Wattage - Version B

115 V - 60 Hz

Panels

Stainless Steel

Side panels

Available in different colors and materials



STONE

Reinventing the coffee space.

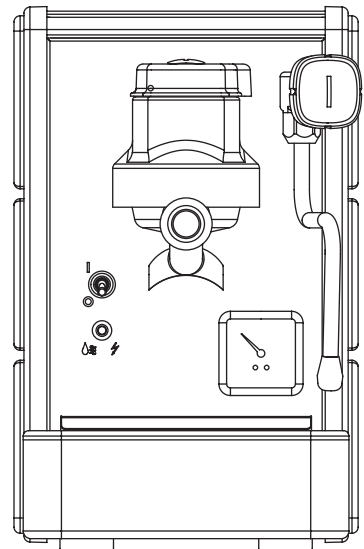

Deutsch

Eine Kaffeemaschine, die Ihre Lieblingskaffeemischungen zur Geltung bringt. Mit Stone werden Sie jede Note Ihres Espressos genießen können. Keine Kompromisse mehr - geben Sie sich Ihrer Leidenschaft für Kaffee hin.



Ihre Küche wird zu einem Gourmet-Café.



Optimale Temperaturbeständigkeit, besseres Ergebnis in der Tasse. Schön und kompakt, aber ohne Kompromisse. Das Design von Stone ist ansprechend und seine Temperaturbeständigkeit überzeugt. Keine Kunststoffteile, nur Metall für ein wesentlich besseres und konstanteres Ergebnis in der Tasse.

Schnelles Aufheizen.

STONE ist in nur 10 Minuten einsatzbereit. So sparen Sie Zeit und können Ihren Kaffee oder Cappuccino in aller Ruhe genießen und so wunderbar in den Tag starten.

Innovation nimmt Gestalt an.

STONE ist aus hochwertigen Materialien gefertigt und besticht durch sein einzigartiges Design und seine professionelle Technik in kompakter Haushaltsgröße.

Das Vergnügen der Wahl.

Entdecken Sie alle Stilkombinationen und wählen Sie den Stone, der am besten zu Ihnen passt. Sie haben die Wahl- bei stets höchster Qualität.

Pure

Seitenwand: Grau



Slab: Grau

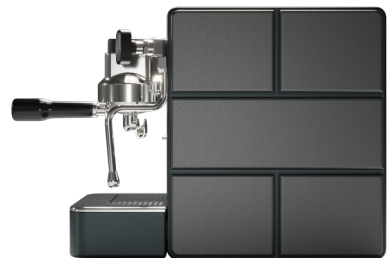

Plus

Seitenwand: Schwarz



Slab: Schwarz



Mine

Seitenwand: Satin



Slab: Schwarz, Grün

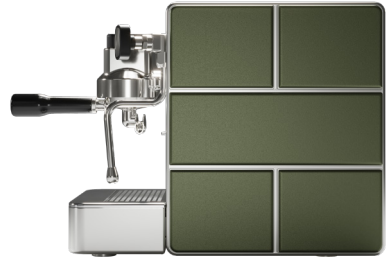

Mine Premium

Seitenwand: Chrom



Slab: Satin



Mine Premium Wood

Seitenwand: Chrom



Slab: Holz



Passen Sie STONE an Ihren Einrichtungsstil an.

Egal ob rustikal oder Industrial Style
-was auch immer Ihr Küchenstil sein mag,
mit Slab wählen Sie das Design, das in
Ihren Raum passt.





STONE verändert sich mit Ihnen.

Dank des Schnellkupplungssystems ist der Austausch der Slabs schnell und einfach. Wenn Sie also Ihr Haus oder Ihren Einrichtungsstil ändern, kann sich STONE mit Ihnen verändern.

Innovation nimmt Gestalt an.

- **Zweikreiser (1,5 l)**, ausgestattet mit einem 1000 W Heizung mit interner Heizspirale zum Erhitzen des Kaffeewassers (100 cc).
- **Schwere Brühgruppe aus Messing (>3 kg)** und PID-geregeltes Heizsystem (200 W) für eine stabile und gleichbleibende Brühtemperatur.
- **Dampfkammer 0,8 l** für dauerhaften Dampfzufuhr selbst bei der Kaffeebrühen.
- **Herausnehmbarer Wasserbehälter (1,2 l)**.
- **ECO-Modus erhältlich**.
- **RGB-LED-Kontrolllicht** für Maschinenstatus und Warnungen.
- **Kompakte Abmessungen:** 22,5 cm x 44 cm x 35,5 cm (Breite x Tiefe x Höhe).
- **Gesamtgewicht:** 20,5 kg.
- **220-240V 50/60Hz** und **115V 60Hz** Ausführungen erhältlich.
- **Wände aus Edelstahl und individuell gestaltbare Aluminium-Seitenteile** (unterschiedliche Farben und Materialien erhältlich).
- **Online-Konfigurator** zur individuellen Gestaltung und Bestellung der eigenen Maschine.

Technische Informationen.

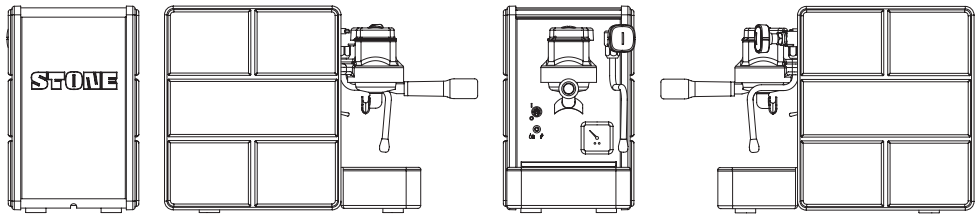

Messungen

Breite
225 mm

Höhe
355 mm

Tiefe
440 mm

Gewicht
20,5 kg

Erhitzer

1000 W

Heizsystem

200 W

Zweikreiser mit Fassungsvermögen

1,5 l

Dampfkammer

0,8 l

Herausnehmbarer Wasserbehälter

1,2 l

Wattleistung - Ausführung A

220-240 V - 50/60 Hz

Wattleistung - Ausführung B

115 V - 60 Hz

Wände

Edelstahl

Seitenwände

In unterschiedlichen Farben und Materialien erhältlich

